

Jarag-5 / PAR30

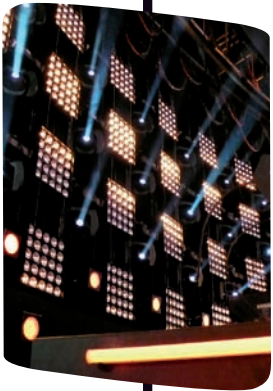

Subtle

Evolved

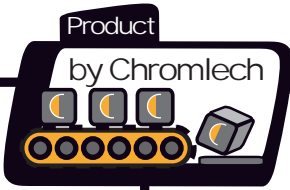
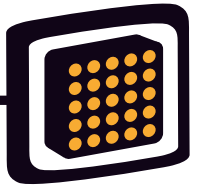
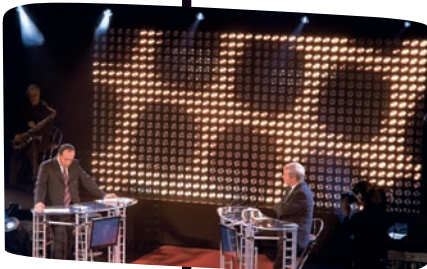

Powerful

Innovating



Overview

Enter the world of the halogen array

Representing a timeless merger between retro and new technology is the Jarag. It provides a complete range of originally shaped projectors and accessories specially conceived to give a broad spectrum of visual effects with unlimited scope for setting up designs.

This modular, extendible system is made of units with individually controlled lamps. This fully integrated, programmable multiple light source system is a simple means of producing lighting effects. The controller is built into the unit for immediate use.

The JARAG uses standard halogen lamps with digital control to give a range of fine, precise shades, from amber to white, with effects ranging from flash transitions to soft, slow variations.

It has never been so easy to set up lamp arrays. Combining several JARAG arrays will create walls of light displaying videos, patterns or animated text. No additional dimmers are required, just a DC supply and a DMX cable. Patterns and animations can be programmed into the system and videos can be sent from advanced DMX consoles or media servers.



Jarag-5 / PAR30

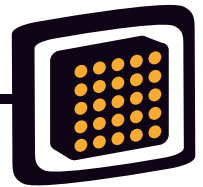

JA221

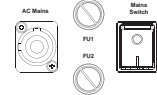
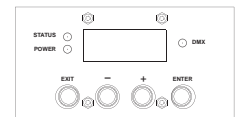
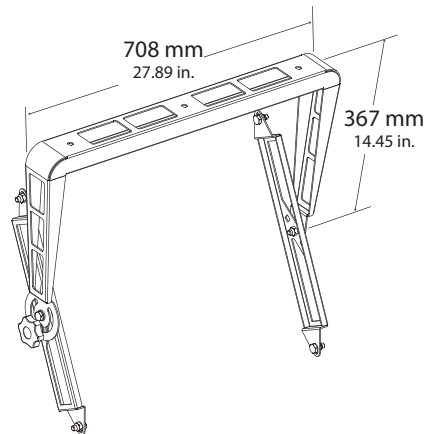
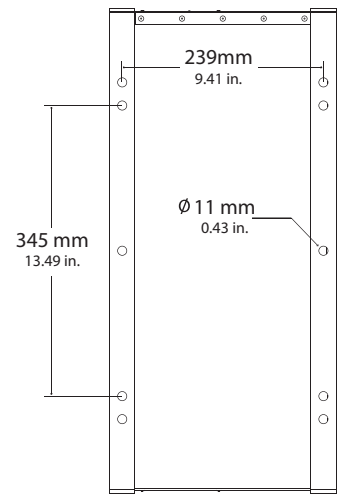
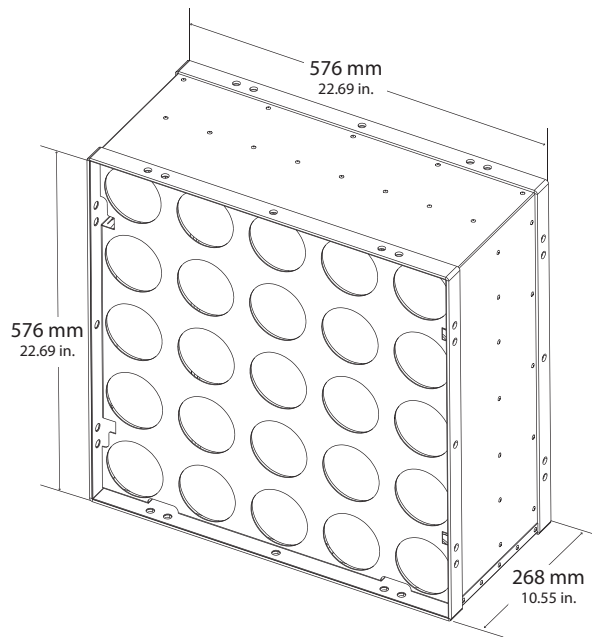

CHROMLECH S.A. - 19, Avenue Gabriel Fauré - 35235 Thorigné-Fouillard - France
Tel : +33 (0) 223 207 767 - Fax : +33 (0) 223 207 571
E-mail : contact@chromlech.com - Web : www.chromlech.com

Specifications

Power supply	Integrated dimmers, 200-230V / 50-60Hz / 8A / 1875 W
Lamps	25 lamps 230V, 75W, Hi-spot 95 type, 10°, 2900K, 3000h, E27, alu reflector
Frame	Aluminium frame, Black epoxy finish
Dimensions	576 x 576 x 270 mm (HxWxD)
Weight	8,6 Kg (without lamps) - 13,1 Kg (with lamps) - Yoke : 4,3 Kg
Rigging	With adjustable yoke and/or frame's rigging point.
Assembly	JARAGs can be juxtaposed and assembled together while preserving a constant lamp's grid spacing
Connectors	Powercon 20A, DMX in (XLR5), DMX out (XLR5), liaison RS232-C (SUBD9)
Control	DMX : 6, 25, or 6+25 channels The integrated sequencer is controlled through 6 DMX channels (intensity, speed, effects/fade, rotation/symmetry, sequence selection), and manages up to 256 sequences of 32 steps. 128 sequences are factory programmed, 128 others sequences are available for user.

CHROMLECH

19, avenue Gabriel Fauré - 35235 Thorigné-Fouillard - France
Tel : +33 (0) 223 207 767 - Fax : +33 (0) 223 207 571
E-mail : contact@chromlech.com - Web : www.chromlech.com